

VALQUA No. 6502 / 6500 / 6500AC / 6503 / 6503AC



## White Compressed Non-Asbestos Fiber Sheet

VALQUA No.  
**6503**

Since black components are removed in the Compressed Fiber Sheet, these gaskets are suitable to be used for applications where inclusion of black foreign substances into the fluid should be avoided.

**Unsuitable fluids** Strong acid, strong alkali, and various solvents, inflammable gas, gas susceptible to burn and toxic gas

**Applications** Applications should be avoided in which black foreign substances are included into process fluids, such as in petrochemical industry.

**Dimensions** <Width × Length> (mm)  
1270 × 1270, 1270 × 3810, 2540 × 3810, 3048 × 3810  
<Thickness> (mm)  
0.5, 0.8, 1.0, 1.5, 2.0, 3.0  
<Color type> white  
<Print color> green



## Anti-corrosion white Compressed Non-Asbestos Fiber Sheet

VALQUA No.  
**6503AC**

With reduced amount of leachable chloride, these white Compressed Fiber Sheets have corrosion suppression effect on stainless steel flanges. Surface finishing reduces sticking to the flange

**Unsuitable fluids** Strong acid, strong alkali, and various solvents, inflammable gas, gas susceptible to burn and toxic gas

**Applications** Pipe flanges, valve bonnets and other equipment used in various industries requiring corrosion resistance for white applications.

**Dimensions** <Width × Length> (mm)  
1270 × 1270, 1270 × 3810, 2540 × 3810  
<Thickness> (mm)  
0.5, 0.8, 1.0, 1.5, 2.0, 3.0  
<Color type> white  
<Print color> orange

## ■ Design data ■

## ▼Recommended tightening stress

Tightening stress is defined as a pressure required under standard conditions without consideration for the opening force due to internal fluid.

Fluid	Recommended tightening stress (MPa)
Liquid	25.5
Gas	40.0

## ▼m,y values

The m, y values for Compressed Fiber Sheets defined in the Appendix G of JIS B 8265 can be applied to the m, y values of Compressed Non-Asbestos Fiber Sheets.

Thickness (mm)	Gasket factor "m"	Minimum design seating stress "y" (N/mm <sup>2</sup> )
3.0	2.00	11.0
1.5	2.75	25.5
1.0	3.50	44.8

## ▼Available ranges

Temperature and pressure classifications show individual service limits.

VALQUA No.	Temperature (°C) <sup>(1)</sup>	Pressure (MPa)		
		Water based	Oil based <sup>(2)</sup>	Gas
6500 / 6500AC	-50~183	3.0	3.0	1.0
6502 / 6503 / 6503AC	-50~214	3.0	3.0	1.0

Notes (1) For service conditions exceeding 100°C, please refer to Khong Lieng team.

(2) Regarding oil gas, solvent and corrosive fluid, separate consultation is required

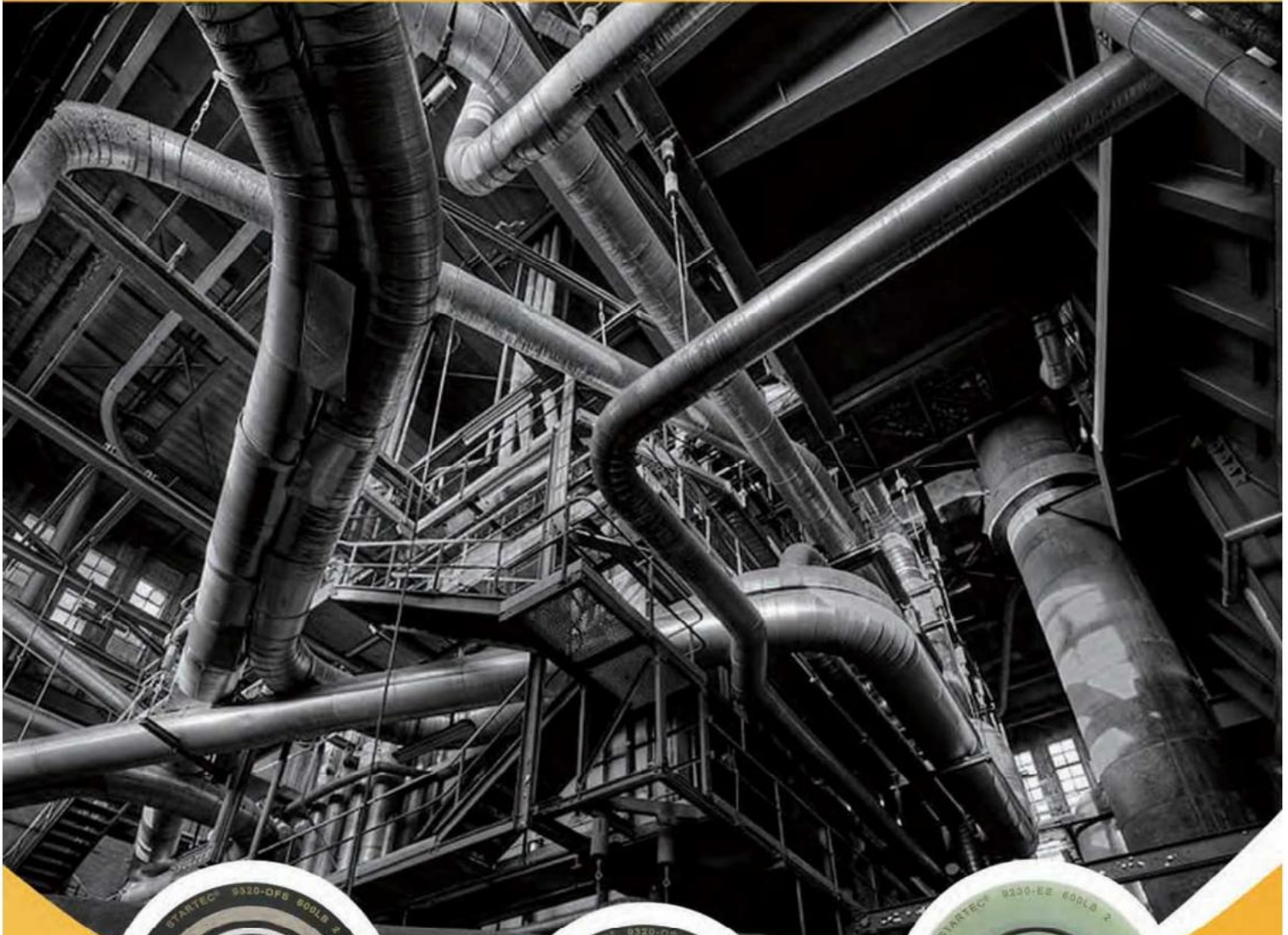

# STARTEC<sup>®</sup> GASKET

## Special Insulation Gasket Series



# STARTEC® 9230-ES Gasket

Seal Material Laminated Epoxy Flange Gasket

## 1. Description

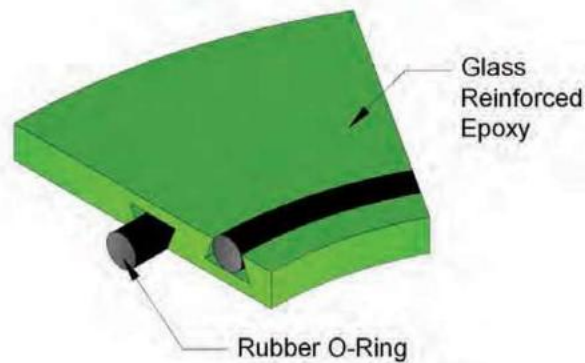

Picture 1. STARTEC® 9230-ES Cross Section

STARTEC® 9230-ES is designed for Medium-pressure service gasket, which is required on electrical insulation and prevent from electrical corrosion where connected with dissimilar metals, and protect flange face damages by low pressure.

To enhance sealing ability and isolation performance, Glass Reinforced Epoxy is reinforced on both surface of sealing Material. Considering applicable Line, specified Elastomer material is adaptable and both Full Face and Flat Ring types are available upon request

## 2. Composition

### Sealing Retainer

STARTEC® 9230-ES retainer is constructed of Glass Reinforced Epoxy laminates and shows excellent dielectric strength and protect the leakage from high pressure, deformation of exterior fluid and inflow.

### Sealing Material

Sealing Material is the most important factors, which defines the sealing ability and should consider each chemical characteristic, temperature and pressure condition. Furthermore, it designed by circumstance damages and deformations for proper sealing.

The sealing retainer of STARTEC® 9230-ES is excellent in minimizing outside fluid contamination and inflow.

### Benefits of STARTEC® 9230-ES

- A. Superior Sealing ability for Medium pressure (Class 150~600) Line
- B. High strength of Sealing retainer prevent damages from excess compression
- C. Excellent insulation performance.
- D. Protection for electrical corrosion in dissimilar metals.
- E. Protection for damage of Facing surfaces
- F. Easy installation and disassembly
- G. Stable Sealability at irregularities and unevenness flange surface



# STARTEC® 9320-OS Gasket

Glass Reinforced Epoxy Faced Metal Plate with PTFE Seal Gasket

## 1. Description

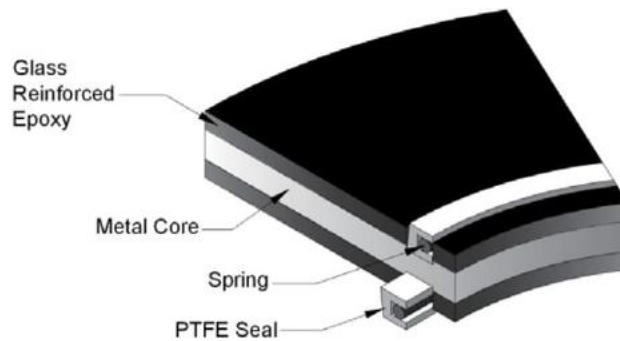

Picture 2. STARTEC® 9320-OS Cross Section

STARTEC® 9320-OS provides excellent solution for electrical flange insulation and generally used for high-pressure services. It is installed in the connection of dissimilar flange materials where protection of electrical corrosion desired.

Attached Spring Reinforced PTFE Seal on Glass-Reinforced Epoxy performs superior sealing ability for low-pressure service.

## 2. Composition

### Metal Core

Attached Stainless Metal Core between Glass Reinforced Epoxy performs superior sealing ability and reinforced insulation characteristic in high pressure. (Max ASME Class 2500)

Standard core Material is Stainless Steel 316L and other special material options are available depend on client requests.

### Sealing Material

The laminate material of STARTEC 9320-OS is composed with Glass Reinforced Epoxy (NEMA LI-1 G10, G11) for excellent insulation.

It protects from leakage on over tightening bolt and penetration of fluids induced erosion with deformation.

### Spring Reinforced PTFE Seal

The selection of sealing material is critical and should be considered its reliability such as each chemical fluid characteristic, temperature and pressure etc.

It is designed for safety from environmental aggressive sealing situation of damages and deformation.

Specially, STARTEC® 9320-OS is minimized Cold Flow by attaching reinforced spring (Stainless Steel) on PTFE Seal. Reliable sealing in using micro-vibration or deformation by loosening bolts is available.



## STARTEC® 9320-OS Gasket

Glass Reinforced Epoxy Faced Metal Plate with PTFE Seal Gasket

### 3. Advantages of STARTEC® 9320-OS

- A. Superior Sealing and Insulating ability.
- B. High Pressure (Max ASME Class 2500)
- C. Excellent Isolation using NEMA LI-1 G10, G11.
- D. Protection for electrical corrosion in dissimilar metals.
- E. High strength of sealing retainer prevents damages from excess compression.
- F. Easy installation and disassembly.
- G. Available for Ring Joint Flange and Raise Face Flange

### 4. Hydro Test Result

- 600LB 2" Raise Faced Flange, Hydraulic 180 kgf/cm<sup>2</sup>: 360 hours No Leak

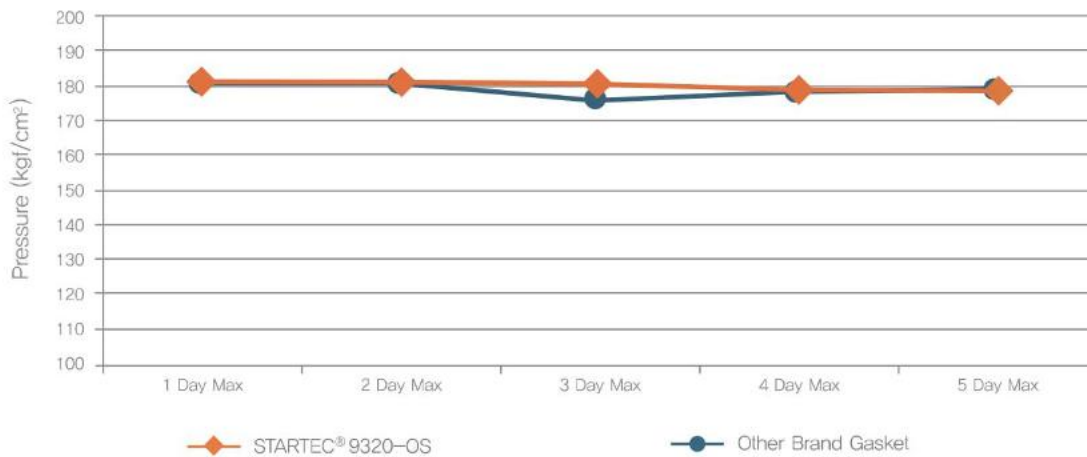

Picture 2. STARTEC® 9320-OS hydraulic Test Result



# STARTEC® 9320-OFS : Fire Safe Gasket

Metal Reinforced Epoxy Plate with fire Safety Double Seal Gasket

## 1. Description



Picture 4. STARTEC® 9320-OFS Cross Section

STARTEC® 9320-OFS is specially invented for raised concern in the event of a fire where existing high pressure fluid line of electrical isolation. Reinforced unique double sealing structure will compensate for the possible risk of a fire, threaten properties caused by non-metallic sealing performance.

Suitable for off shore industry and project purpose where mandatorily required to prevent 2<sup>nd</sup> damage from fluids leakage likely happen to high risk or explosion caused by a fire.

## 2. Composition

### Metal Core

Inserted metal core on both surfaces of Glass Reinforced Epoxy, it designed to support in high pressure rate of Max ASME 2500 and can withstand to applying the condition.

Standard core Material is Stainless Steel 316L and other special material options are available depend on client requests.

### Spring Reinforced PTFE Seal

The selection of sealing material is important and requires considering its reliability such as each chemical fluid characteristic, temperature and pressure etc. It is highly designed for safety from environmental aggressive sealing situation of damages and deformation.

Specially, STARTEC® 9320-OFS is minimized Cold Flow by attaching reinforced spring (Stainless Steel) on PTFE Seal. Reliable sealing in using micro-vibration or deformation by loosening bolts is available.

### Glass Reinforced Epoxy Plate

The laminate material of STARTEC® 9320-OFS is composed with Glass Reinforced Epoxy (NEMA LI-1 G10, G11), which shown stable insulation and leakage safety during over tightening. Excellent protect from the interferences of fluids penetration including erosion with deformation.

### Serrated Metal Gasket with STARPITE®

The secondary seal of serrated metal gasket with reinforced STARTEC® Insulating layer shall minimize the leakage damage after the primary PTFE sealing and glass reinforced epoxy have melted by the fire in the high temperature.

Standard core Material is Stainless Steel 316L and other special material options are available depend on client requests.



# STARTEC® 9320-OFS : Fire Safe Gasket

Metal Reinforced Epoxy Plate with fire Safety Double Seal Gasket

## 3. Advantages of STARTEC® 9320-OFS

- A. Stable sealability and insulation performance on severe condition
- B. Reinforced metal core applicable on ASME Class 2500 with
- C. Better compressive strength and heat resistance by using NEMA G11
- D. Protection for electrical corrosion in dissimilar metal connection.
- E. High strength of sealing retainer prevents damages from excess compression.
- F. Easy installation and disassembly.
- G. Stable performance with double sealing structure of serrated gasket.
- H. Certifying API 6FB Fire Test (See Chapter 5 API 6FB Fire Test Result)

## 4. Hydraulic Test Result of STARTEC® 9320-OFS

- 600LB 2" Raise Faced Flange, Hydraulic 180kgf/cm<sup>2</sup> : 360 hours No Leak



## 5. API 6FB Fire Test

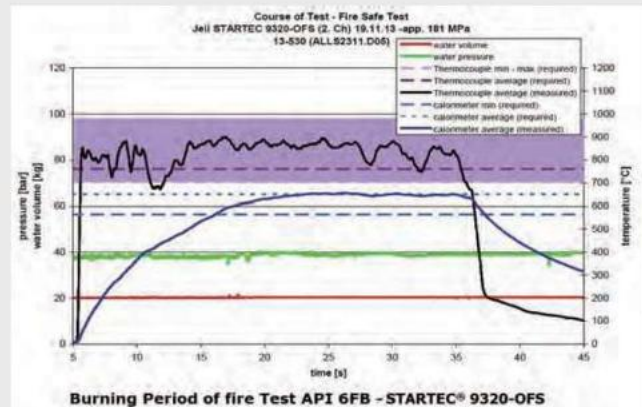

The Fire test according to API 6FB(dated December 2008) requires that any sealing end connection hold 30 minutes in a flame condition and then for a cool down period. After the assembly is cooled down to 100°C or less the line is depressurized and then re-pressurized. During all facets of the test the gasket must not exceed an API proscribed leak rate. In the fire test a 6" Class 300 flange is pressurised with a test pressure of 75% of the API rated working pressure. The Test pressure is maintained during the burn and cool-down period. After 5 minutes a fire is established and the flame temperature is monitored. The average of the thermocouples must reach 760°C within 2 minutes and the average of the calorimeter shall reach 650°C within 15 minutes. The burn period shall last for 30 minutes. After the burn period the connection is air-cooled down to 100°C or less. After cooling down the flange is depressurized and the pressure is increased again to the test pressure and held for 5 minutes.

The maximum leak rate is 1 ml/inch per minute of mean gasket circumference.

- Leak rate acceptance Criteria : Max 1.0 ml/inch/min
- 9320-OFS Leak rate Result : 0.2 ml/inch/min



## Additional Insulation Set Material

Item	Description	Temp. Range(°C)	Insulation Resistance (Ω)
	JIC CODE / EQ	Pressure CLASS	
	PTFE SO LID Gasket	-100 °C ~100 °C / 150LB	Over 2.0 × 10 <sup>13</sup> Ω
	JIC 8305		
	REINFORCED PTFE Gasket	-200 °C ~200 °C / 300LB	1.3 × 10 <sup>11</sup> Ω
	JIC 8305G		
	Neoprene Faced Phenolic Gasket	-30 °C ~120 °C / 150LB	CR 1.6 × 10 <sup>7</sup> Ω
	JIC 9020 -CP		
	STARTEC® Gasket (Glass Reinforced Epoxy Plate Gasket With Rubber O -Ring)	-40 °C ~150 °C / 600LB	EPDM Over 2.0 × 10 <sup>13</sup> Ω
	JIC 9210 -ER		
	STARTEC® Gasket (Glass Reinforced Phenolic Plate Gasket with Rubber O -Ring)	-40 °C ~150 °C / 600LB	VITON 9.7 × 10 <sup>9</sup> Ω
	JIC 9220 -PR		
	STARTEC® Gasket (Glass Reinforced Epoxy Plate Gasket With Rubber O -Ring)	-60 °C ~150 °C / 600LB	NBR 1.3 × 10 <sup>11</sup> Ω
	JIC 9230 -ES / EQ : PIKOTEK PGE TYPE		
	STARTEC® Gasket (Glass Reinforced Epoxy Faced Metal Plate with Rubber O -Ring)	Max 150 °C / 1500LB	
	JIC 9310 -OS / EQ : PIKOTEK VCS TYPE		
	STARTEC® Gasket (Glass Reinforced Epoxy Faced Metal Plate with PTFE Seal)	Max 150 °C / 2500LB	Over 2.0 × 10 <sup>13</sup> Ω
	JIC 9320 _OS / EQ : PIKOTEK VCS TYPE		
	STARTEC® Gasket (Metal Reinforced Epoxy Plate with fire Safety Double Seal Gasket)	Max 200 °C / 2500LB	Over 2.0 × 10 <sup>13</sup> Ω
	JIC 9320 -OFS / EQ : PIKOTEK VCFS TYPE		
	KAMMPROFILE GASKET WITH STARPITE®	Max 1000 °C / 2500LB	9.9 × 10 <sup>10</sup> Ω
	JIC 3850 -SE(HT)		

\* Insulation Resistance(Ω) ASTM D257-07: Usage Voltage: 1000V, Capacity of Tester : 2.0 × 10<sup>13</sup> Ω

\* Gasket shall be selected client preference, but individual dimension approval is required.

\* PTFE Gasket is not recommended on R.F Type because of creep characteristic.



## Additional Insulation Set Material

### - Insulation Set Material – Bolt/Nut/Sleeve/Washer

Composition	Description	Insulation ( $\Omega$ )		
INSULATION SLEEVE	GLASS REINFORCED EPOXY (GRE)	Over $2.0 \times 10^{13}\Omega$	150	0.8T ~ 1.0T
	PHENOLIC	$2.2 \times 10^8\Omega$	180	
	PTFE	Over $2.0 \times 10^{13}\Omega$	100	
	MICA	$9.9 \times 10^{10}\Omega$	1000	
INSULATION WASHER	GLASS REINFORCED EPOXY(GRE)	Over $2.0 \times 10^{13}\Omega$	150	3.0T
	PHENOLIC	$2.2 \times 10^8\Omega$	180	
	MICA	$9.9 \times 10^{10}\Omega$	1000	
STEEL WASHER	CARBON STEEL	N/A	N/A	3.0T
	STAINLESS STEEL	N/A	N/A	~ 5.0T
NUT	A194 Gr.2H (ASTM)	N/A	N/A	-
	A194 Gr.8 (ASTM)	N/A		
	A194 Gr.8M (ASTM)	N/A		
BOLT	A193 Gr.B7 (ASTM)	N/A	N/A	-
	A193 Gr.B8 (ASTM)	N/A		
	A193 Gr.B8M (ASTM)	N/A		

\* Insulation Resistance( $\Omega$ ) ASTM D257-07: Usage Voltage: 1000V, Capacity of Tester :  $2.0 \times 10^{13}\Omega$

\* Various material and coating are available as customer's requirement.

\* For non-standard flange insulation set application, please consult with Khong Lieng team.

### - Insulation Material Property Chart

Test Name	Typical Result			
	Phenol	NEMA G-10	NEMA G-11	MICA
Compressive Strength (PSI)	58,000	57,000	65,000 (60,400 at 130 °C)	-
Dielectric Strength (Volts/mil)	550	625	800	508
Tensile Strength (PSI)	32,000	52,000	52,000	1,450~2,900
Water Absorption (%)	-	0.02~0.04	0.02~0.04	-
Applicable Temp (°C)	180	150	180	1,000

Why

Environmentally Friendly Solvent Free Process  
**LEAKBLOK**<sup>®</sup>?

for customers  
around the World

- L**ower Costs for Client (Time/Process/Handle etc)
- E**co-Friendly for Client's Purpose
- A**ggressive Sales with LEAKBLOK<sup>®</sup>
- K**eeping Workshop Clean & Tiny
- B**esides, Make your Plants SAFE
- L**eading the Market with LEAKBLOK<sup>®</sup>
- O**vious way to get good Productivities
- K**orean Origin from JEIL's TECH Support



# LEAKBLOK<sup>®</sup> Properties

Grade		LEAKBLOK <sup>®</sup> Premium			
Composition		Aramid Fiber Glass Fiber NBR Binder	Aramid Fiber Glass Fiber NBR Binder	Aramid Fiber Glass Fiber SBR Binder	Aramid Fiber Glass Fiber NBR Binder
Model No		P100	P200	P300	P400
Basic Color		Green	Blue	Silver	Brown
Temperature	Continuous Operating(°C)	-50~180	-150~220	-150~220	-150~260
	Short-term peak(°C)	-100~260	-196~350	-196~350	-196~430
Pressure	Short-term peak(bar)	60	80	80	100
<b>Test Method</b>	<b>Physical Properties</b>	<b>P100</b>	<b>P200</b>	<b>P300</b>	<b>P400</b>
ASTM D792	Density[g/cm <sup>3</sup> ]	1.9	1.9	1.9	1.9
ASTM F152	Tensile strength Across grain MPa[kg/cm <sup>2</sup> ]	10.0 (102)	15.0 (153)	15.0 (153)	16.7 (170)
ASTM F36J	Compressibility[%]	10	9	9	8
ASTM F36J	Recovery[%]	75	71	73	63
ASTM F146	Fluid Resistance after 5hrs immersions ASTM # 3 oil(150°C) Thickness Increase[%]	4	3	10	4
	ASTM Fuel B(20~30°C) Thickness Increase[%]	7	6	10	4
	Weight Increase[%]	10	9	17	12
DIN 52913	Relaxation Stress[MPa]				
	- 50MPa 16hrs / 175°C	20	38.2	37.6	-
	- 50MPa 16hrs / 300°C	-	-	-	38.2
BS 7531	Relaxation Stress[MPa] - 40MPa 16hrs / 300°C	-	23.7	23.8	25.1
VDI 2440 (TA-LUFT)	Leak rate [mbar.l/(s.m)]	2x10 <sup>-8</sup>	2x10 <sup>-8</sup>	2x10 <sup>-8</sup>	2x10 <sup>-8</sup>
DIN 3535/6	Gas Permeability[ml/min]	≤ 0.01	≤ 0.01	≤ 0.01	≤ 0.01
Type Approval & Test Certificate		ISO 9001/14001/18001, PED, NET Lloyd's & ABS TA, TA-Luft, WRAS, Fire Endurance Test(ISO 19921 & 19922)			
pH Range		4-11 Above is general range and has no guarantee for every case. Please contact us for further details.			
Thickness		0.8mm ~ 3.2mm			
Width		1270mm(50"), 1500mm(60")			
Length		1270mm(50"), 1500mm(60"), 3M~10M, 15M~20M & ETC (Please consult to maximum length with Khong Lieng sales team.)			
Applicable Fluids		Portable Water, Oils, Fuels Salt Solution, gas line, Mild acids and alkalis & ETC			

\* All data are 1.5mm thickness typical value.

\* 상기 물성치는 1.5t 제품의 실측값이며, 전체물성을 대표하지는 않음.

# Compressed Asbestos-Free Gasket **LEAKBLOK® Premium P200**

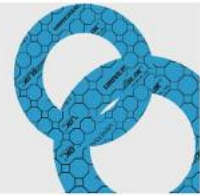

MATERIAL PROPERTIES		SERVICE RANGE
<b>Product Name</b>	LEAKBLOK® Premium P200	<p><b>Area (A)</b> Satisfactory area subject to chemical compatibility</p> <p><b>Area (B)</b> Usually suitable but required technical recommend by JEIL Technical team</p> <p><b>P×T(Max)</b> psi × °F (bar × °C) / 496,480 (17,600)</p>
<b>Color</b>	Blue(Black Printed)	
<b>Composition</b>	Aramid Fiber + NBR Binder	
<b>Fluids Service</b>	Portable Water, Oils, Fuels, Salt Solution, Mild acids and alkalis, gas line	
<b>Pressure</b>	Short-term peak 80bar (1160 psi)	
<b>Temperature</b>	Continuous -150 °C (-238°F) ~ 220 °C (428°F)	
	Short-term peak -196 °C (-321°F) ~ 350 °C (660°F)	
<b>pH range</b>	4-11	
<b>Thickness</b>	0.8 ~ 3.2(mm)	
<b>Size</b>	1270(W)×1270(L), 1500(W)×1500(L) Available in Rolls.	
<b>Certificates</b>	Lloyd's & ABS Type Approval , TA-Luft(VDI 2440), WRAS, BS 7531 Grade Y Fire Endurance Test(ISO 19921 & 19922)	

PHYSICAL PROPERTIES			IMMERSION PROPERTIES		
<b>Test Method</b>	<b>Description</b>	<b>LEAKBLOK® P200</b>	<b>Test Method</b>	<b>Description</b>	<b>LEAKBLOK® P200</b>
ASTM D792	Density (g/cm³)	1.9	ASTM F146		
ASTM F152	Tensile Strength Across grain.MPa (kgf/mm²)	15.0(1.53)	at 150°C x5hrs		
ASTM F36 Procedure J	Compressibility (%)	9	ASTM Oil no 3	Thickness Increase (%)	3
DIN 3535 -6	Recovery (%)	71	at 20~30 °C x5hrs		
DIN 52913	Gas permeability (ml/min)	≤ 0.01	ASTM Fuel B	Thickness Increase (%)	6
BS 7531	Relaxation Stress(MPa)			Weight Increase (%)	9
	- 50MPa 16 hours @175°C	38.2	<b>GASKET DESIGN DATA</b>		
	- 40MPa 16 hours @300°C	23.7	<b>Thickness (mm)</b>	<b>Gasket Factor(m)</b>	<b>Min. Design Seating Stress(y) Kgf/cm² (psi)</b>
VDI 2440 (TA - Luft)	Leak rate ( mbar.l / (s.m) )	2·10 <sup>-8</sup>	3.2	2.00	112(1600)
	-at 150°C 48 hours		1.6	2.75	260(3700)
			0.8	3.50	457(6500)

\* All data are 1.5mm thickness typical value.

Innovative technology, LEAKBLOK®, absolutely distinguished from the traditional way of calendar roll production, It specially invented with environmentally friendly solvent free process. Compare with previous product, it shows strong durability and superior at low seating stress. Suitable for use steam and clean line, excellent protection of fluid contamination.

**WARNING**

- Not available with max. temperature & pressure at the same time
- Guide line only, if outside this range contact us.
- Do not re-use gaskets unless this is specifically indicated.
- Do not use gasket compounds with gasket as this will adversely affect performance.
- Please consult with Khong Lieng team for application of steam & explosive gas line especially.
- Please consult to maximum length with Khong Lieng sales team.

# Compressed Asbestos-Free Gasket **LEAKBLOK<sup>®</sup> Premium P300**



MATERIAL PROPERTIES		SERVICE RANGE
Product Name	LEAKBLOK <sup>®</sup> Premium P300	<p>Area (A) Satisfactory area subject to chemical compatibility Area (B) Usually suitable but required technical recommend by JEIL Technical team P x T(Max) psi x °F(bar x °C) / 496,480(17,600)</p>
Color	Silver(Black Printed)	
Composition	Aramid Fiber + SBR Binder	
Fluids Service	Portable Water, Oils, Fuels, Salt Solution, Mild acids and alkalis, gas line	
Pressure	Short-term peak 80bar (1160 psi)	
Temperature	Continuous -150 °C (-238 °F) ~ 220 °C (428 °F)  Short-term peak -196 °C (-321 °F) ~ 350 °C (660 °F)	
pH range	4-11	
Thickness	0.8 ~ 3.2(mm)	
Size	1270(W)x1270(L), 1500(W)x1500(L) Available in Rolls.	
Certificates	Lloyd's & ABS Type Approval , TA-Luft(VDI 2440), WRAS, BS 7531 Grade Y Fire Endurance Test(ISO 19921 & 19922)	

PHYSICAL PROPERTIES			IMMERSION PROPERTIES		
Test Method	Description	LEAKBLOK <sup>®</sup> P300	Test Method	Description	LEAKBLOK <sup>®</sup> P300
ASTM D792	Density (g/cm <sup>3</sup> )	1.9	ASTM F146		
ASTM F152	Tensile Strength Across grain.MPa (kgf/mm <sup>2</sup> )	15.0(1.53)	at 15 °C x5hrs		
ASTM F36 Procedure J	Compressibility (%) Recovery (%)	9 73	ASTM Oil no 3	Thickness Increase (%)	10
DIN 3535 -6	Gas permeability (ml/min)	≤ 0.01	at 20~30°C x5hrs		
DIN 52913	Relaxation Stress(MPa) - 50MPa 16 hours @175°C	37.6	ASTM Fuel B	Thickness Increase (%) Weight Increase (%)	10 17
BS 7531	Relaxation Stress(MPa) - 40MPa 16 hours @300°C	23.8			
VDI 2440 (TA - Luft)	Leak rate ( mbar.l /(s.m) ) -at 150°C 48 hours	2·10 <sup>-8</sup>	<b>GASKET DESIGN DATA</b>		
			Thickness (mm)	Gasket Factor(m)	Min. Design Seating Stress(y) Kgf/cm <sup>2</sup> (psi)
			3.2	2.00	112(1600)
			1.6	2.75	260(3700)
			0.8	3.50	457(6500)

\* All data are 1.5mm thickness typical value.

Innovative technology, LEAKBLOK<sup>®</sup>, absolutely distinguished from the traditional way of calendar roll production, It specially invented with environmentally friendly solvent free process.  
Compare with previous product, it shows strong durability and superior at low seating stress.  
Suitable for use steam and clean line, excellent protection of fluid contamination.

### WARNING

- Not available with max. temperature & pressure at the same time
- Guide line only, if outside this range contact us.
- Do not re-use gaskets unless this is specifically indicated.
- Do not use gasket compounds with gasket as this will adversely affect performance.
- Please consult with Khong Lieng team for application of steam & explosive gas line especially.
- Please consult to maximum length with Khong Lieng sales team.

# Compressed Asbestos-Free Gasket **LEAKBLOK<sup>®</sup> Premium P400**



MATERIAL PROPERTIES		SERVICE RANGE	
Product Name	LEAKBLOK <sup>®</sup> Premium P400	<p><b>Area (A)</b> Satisfactory area subject to chemical compatibility</p> <p><b>Area (B)</b> Usually suitable but required technical recommend by JEIL Technical team</p> <p><b>P×T(Max)</b> psi ×°F(bar×°C) / 725,000(26,000)</p>	
Color	Brown(Black Printed)		
Composition	Aramid Fiber + NBR Binder		
Fluids Service	Portable Water, Oils, Fuels, Salt Solution, Mild acids and alkalis, gas line		
Pressure	Short-term peak 100bar (1450 psi)		
Temperature	Continuous -150 °C (-238°F) 260 °C (500°F)  Short-term peak -196 °C (-321°F) 430 °C (806°F)		
pH range	4-11		
Thickness	0.8 ~ 3.2(mm)		
Size	1270×1270, 1500×1500 (mm) Available in Rolls.		
Certificates	Lloyd's & ABS Type Approval , TA-Luft(VDI 2440), WRAS, BS 7531 Grade X Fire Endurance Test(ISO 19921 & 19922)		

PHYSICAL PROPERTIES			IMMERSION PROPERTIES		
Test Method	Description	LEAKBLOK <sup>®</sup> P400	Test Method	Description	LEAKBLOK <sup>®</sup> P400
ASTM D792	Density (g/cm <sup>3</sup> )	1.9	ASTM F146	at 150 °C ×5hrs	
ASTM F152	Tensile Strength Across grain. MPa (kgf/mm <sup>2</sup> )	16.7(1.70)	ASTM Oil no 3	Thickness Increase (%)	4
ASTM F36 Procedure J	Compressibility (%) Recovery (%)	8 63	at 20~30 °C ×5hrs		
DIN 52913	Relaxation Stress(MPa) - 50MPa 16 hours @300°C	38.2	ASTM Fuel A	Thickness Increase (%)	1
BS 7531	Relaxation Stress(MPa) - 40MPa 16 hours @300°C	25.1	ASTM Fuel B	Thickness Increase (%)	4
DIN 3535 -6	Gas permeability (ml/min)	≤ 0.01	<b>GASKET DESIGN DATA</b>		
VDI 2440 (TA - Luft)	Leak rate ( mbar.l / (s.m) ) - at 150°C 48 hours	2·10 <sup>-8</sup>	Thickness (mm)	Gasket Factor(m)	Min. Design Seating Stress(y) Kgf/cm <sup>2</sup> (psi)
			3.2	2.00	112(1600)
			1.6	2.75	260(3700)
			0.8	3.50	457(6500)

\* All data are 1.5mm thickness typical value.

Innovative technology, LEAKBLOK<sup>®</sup>, absolutely distinguished from the traditional way of calendar roll production, It specially invented with environmentally friendly solvent free process. Compare with previous product, it shows strong durability and superior at low seating stress. Suitable for use steam and clean line, excellent protection of fluid contamination.

### WARNING

- Not available with max. temperature & pressure at the same time
- Guide line only, if outside this range contact us.
- Do not re-use gaskets unless this is specifically indicated.
- Do not use gasket compounds with gasket as this will adversely affect performance.
- Please consult with Khong Lieng team for application of steam & explosive gas line especially.



JDV  
CONTROL  
VALVES



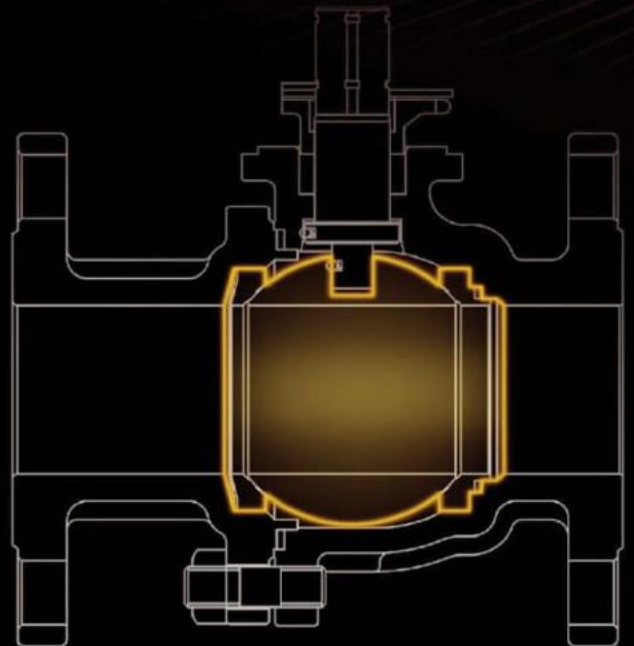

**Technology for the professionals**



# State-of-the-art Engineering

The computerized design, combined with practical product verifications, ensures the reliability and durability of our products.

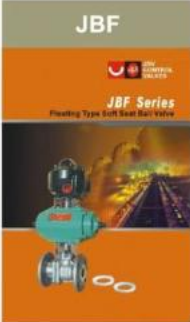

	JSB	JBF	JBFM	JBSM
Series	 <p><b>JSB Series</b> V-Port Baghead Control Valve</p>	 <p><b>JBF Series</b> Floating Type Seal Seal Ball Valve</p>	 <p><b>JBFM Series</b> Floating Type Metal Seal Ball Valve</p>	 <p><b>JBSM Series</b> LPC High Performance Metal Seal Ball Valve</p>
Design	Trunnion Nearly Full-Port	Floating Full-Port	Floating Full-Port	Floating Full-Port
Pressure Rating	ASME CLASS 150/300 DIN PN16/40 JIS 10/20K	ASME CLASS 150/300/600 DIN PN16/40 JIS 10/20K	ASME CLASS 150/300/600 DIN PN16/40 JIS 10/20K	ASME CLASS 600
Size	1"~16" DN25~DN300	1/2"~12" DN15~DN300	1/2"~8" DN15~DN200	1/2"~2" DN15~DN50
Temperature	-29 ~ 350 Deg C -20 ~ 662 Deg F	-29 ~ 250 Deg C -20 ~ 482 Deg F	-29 ~ 500 Deg C -20 ~ 932 Deg F	-29 ~ 350 Deg C -20 ~ 662 Deg F
Body Material	<ul style="list-style-type: none"> <li>• Carbon Steel</li> <li>• Stainless Steel</li> <li>• Duplex</li> <li>• Special materials</li> </ul>	<ul style="list-style-type: none"> <li>• Carbon Steel</li> <li>• Stainless Steel</li> <li>• Duplex</li> <li>• Special materials</li> </ul>	<ul style="list-style-type: none"> <li>• Carbon Steel</li> <li>• Stainless Steel</li> <li>• Duplex</li> <li>• Special materials</li> </ul>	<ul style="list-style-type: none"> <li>• Carbon Steel</li> <li>• Stainless Steel</li> <li>• Duplex</li> <li>• Special materials</li> </ul>
Seat Material	<ul style="list-style-type: none"> <li>• G-PTFE</li> <li>• S-PTFE</li> <li>• PEEK</li> <li>• Metal+Stellite</li> <li>• Metal+TC</li> </ul>	<ul style="list-style-type: none"> <li>• PTFE</li> <li>• R-PTFE</li> <li>• TFM-1600</li> <li>• PEEK</li> </ul>	<ul style="list-style-type: none"> <li>• Metal+Stellite</li> <li>• Metal+TC</li> <li>• Metal+CRC</li> </ul>	<ul style="list-style-type: none"> <li>• Metal+Stellite</li> <li>• Metal+TC</li> <li>• Metal+CRC</li> </ul>
Connection	Wafer Flanged RF/RTJ	Flanged RF/RTJ	Flanged RF/RTJ	Screwed Socket Weld Butt Weld
Applications	<ul style="list-style-type: none"> <li>• Slurries</li> <li>• Viscous mediums</li> <li>• Powders and particles</li> <li>• Chips and fibers</li> <li>• Flow control</li> </ul>	<ul style="list-style-type: none"> <li>• Medium temperature</li> <li>• Clean mediums</li> </ul>	<ul style="list-style-type: none"> <li>• High temperature</li> <li>• Abrasive mediums</li> </ul>	<ul style="list-style-type: none"> <li>• High temperature</li> <li>• Abrasive mediums</li> </ul>



HVOF Coating

# Highly Sophisticated Technology

Our high-quality equipment and latest technology guarantee the optimal performance of the products, even under the toughest conditions.

JBT	JBTM	JCT	JCTM	JBF CRYOGENIC	JBFM CRYOGENIC
					
Trunnion Full-Port	Trunnion Full-Port	Trunnion Full-Port	Trunnion Full-Port	Floating Full-Port	Floating Full-Port
ASME CLASS 150/300/600/900/1500/2500	ASME CLASS 150/300/600/900/1500/2500	ASME CLASS 150/300 DIN PN16/40	ASME CLASS 150/300 DIN PN16/40	ASME CLASS 150/300 DIN PN16/40 JIS 10/20K	ASME CLASS 150/300 DIN PN16/40 JIS 10/20K
2"~24" DN50~DN600	2"~24" DN50~DN600	1-1/2"~8" DN40~DN200	1-1/2"~8" DN40~DN200	1/2"~6" DN15~DN150	1/2"~6" DN15~DN150
-29 ~ 250 Deg C -20 ~ 482 Deg F	-29 ~ 500 Deg C -20 ~ 932 Deg F	-29 ~ 250 Deg C -20 ~ 482 Deg F	-29 ~ 500 Deg C -20 ~ 932 Deg F	-196 ~ 200 Deg C -320 ~ 392 Deg F	-196 ~ 350 Deg C -320 ~ 662 Deg F
<ul style="list-style-type: none"> <li>Carbon Steel</li> <li>Stainless Steel</li> <li>Duplex</li> <li>Special materials</li> </ul>	<ul style="list-style-type: none"> <li>Carbon Steel</li> <li>Stainless Steel</li> <li>Duplex</li> <li>Special materials</li> </ul>	<ul style="list-style-type: none"> <li>Carbon Steel</li> <li>Stainless Steel</li> <li>Duplex</li> <li>Special materials</li> </ul>	<ul style="list-style-type: none"> <li>Carbon Steel</li> <li>Stainless Steel</li> <li>Duplex</li> <li>Special materials</li> </ul>	<ul style="list-style-type: none"> <li>Carbon Steel</li> <li>Stainless Steel</li> <li>Duplex</li> <li>Special materials</li> </ul>	<ul style="list-style-type: none"> <li>Carbon Steel</li> <li>Stainless Steel</li> <li>Duplex</li> <li>Special materials</li> </ul>
<ul style="list-style-type: none"> <li>PTFE</li> <li>R-PTFE</li> <li>TFM-1600</li> <li>PEEK</li> </ul>	<ul style="list-style-type: none"> <li>Metal+Stellite</li> <li>Metal+TC</li> <li>Metal+CRC</li> </ul>	<ul style="list-style-type: none"> <li>PTFE</li> <li>R-PTFE</li> <li>TFM-1600</li> <li>PEEK</li> </ul>	<ul style="list-style-type: none"> <li>Metal+Stellite</li> <li>Metal+TC</li> <li>Metal+CRC</li> </ul>	<ul style="list-style-type: none"> <li>TFM-1600</li> <li>PCTFE (Kel-F)</li> </ul>	<ul style="list-style-type: none"> <li>Metal+Stellite</li> <li>Metal+TC</li> <li>Metal+CRC</li> </ul>
Flanged RF/RTJ	Flanged RF/RTJ	Flanged RF/RTJ	Flanged RF/RTJ	Flanged RF/RTJ	Flanged RF/RTJ
<ul style="list-style-type: none"> <li>Medium temperature</li> <li>Clean mediums</li> <li>High drop pressure</li> </ul>	<ul style="list-style-type: none"> <li>High temperature</li> <li>Abrasive mediums</li> <li>High drop pressure</li> </ul>	<ul style="list-style-type: none"> <li>Medium temperature</li> <li>Clean mediums</li> <li>High drop pressure</li> <li>Diversions</li> </ul>	<ul style="list-style-type: none"> <li>High temperature</li> <li>Abrasive mediums</li> <li>High drop pressure</li> <li>Diversions</li> </ul>	<ul style="list-style-type: none"> <li>Low temperature</li> <li>Clean mediums</li> </ul>	<ul style="list-style-type: none"> <li>Low temperature</li> <li>Clean mediums</li> </ul>

# Strict Quality Control

Meticulous Quality Control procedures have been implemented in every production process and approved by the most important certifications such as ISO 9001, CE/PED, API 6D, TSG, etc., to assure your safety.



**JBK**

JTE CONTROL VALVES

**JBK/JBK Series**  
Floating Type & Full-Port

Floating Full-Port

ASME CLASS 150/300

1/2"~8"  
DN15~DN200

-29 ~ 250 Deg C  
-20 ~ 482 Deg F

- Stainless Steel
- Duplex
- Special materials

- PTFE
- R-PTFE
- TFM-1600
- PEEK

Flanged RF/RTJ

- Medium temperature
- Clean mediums
- Heating or cooling medium temperature

**JBKM**

JTE CONTROL VALVES

**JBK/JBK Series**  
Floating Type & Full-Port

Floating Full-Port

ASME CLASS 150/300

1/2"~8"  
DN15~DN200

-29 ~ 350 Deg C  
-20 ~ 662 Deg F

- Stainless Steel
- Duplex
- Special materials

- Metal+Stellite
- Metal+TC
- Metal+CRC

Flanged RF/RTJ

- High temperature
- Abrasive mediums
- Heating or cooling medium temperature

**JTE/JTEM**

JTE CONTROL VALVES

**JTE Series**  
Triple Offset

Triple Offset

ASME CLASS 150/300/600 /900/1500/2500

3"~72"  
DN80~DN1800

-196 ~ 800 Deg C  
-320 ~ 1472 Deg F

- Carbon Steel
- Stainless Steel
- Special materials

- Metal+Stellite
- Metal+TC
- Metal+CRC

Lug / Wafer  
Flanged Short RF/RTJ  
Flanged Long RF/RTJ

- High temperature
- Abrasive mediums
- High drop pressure

**JEF/JEG**

JTE CONTROL VALVES

**JEF / JEG Series**  
Pneumatic Actuator

**JMO Series**  
Manual Operator

Pneumatic Actuator Rack & Pinion

2.5 ~ 8 Bar  
36 ~ 116 Psi

4 ~ 5,000 Nm  
35 ~ 44,253 In-lb

-35 ~ 150 Deg C  
-31 ~ 302 Deg F

- Aluminium Alloy

- Standard: NBR
- Option: VITON®

ISO 5211  
NAMUR

- Filtered air

**JES/JEC**

JTE CONTROL VALVES

**JES / JEC Series**  
Pneumatic Actuator

Pneumatic Actuator Scotch York

2.8 ~ 7 Bar  
40 ~ 101 Psi

495 ~ 750,000 Nm  
4,386 ~ 6,645,000 In-lb

-35 ~ 150 Deg C  
-31 ~ 302 Deg F

- Ductile Iron

- Standard: NBR
- Option: VITON®

ISO 5211 OR MSS  
NAMUR

- Filtered air

Ball Valve

Butterfly Valve

Accessory



Technology for the professionals

## Medium Pressure Regulators

Type MR  
Pressure Reducing Regulator

Type MS  
Back Pressure Regulator

MADE   
SWISS



### Description

Regulators for medium pressures up to 16 bar.

The ZÜRCHER-TECHNIK pressure regulators join knowledge, experience and know-how of more than 30 years pressure regulator production and marketing.

The high demands and needs by the chemical-pharmaceutical industry have led to develop precise and corrosion resistant pressure regulators.



Pressure regulators in standard design are in use for all industrial applications. The sanitary design regulators are suitable for a variety of applications in the food & beverage, pharmaceutical and biotechnology industries.

### Highlights

- Regulating range up to 16 bar / 300 psi
- Withstands full vacuum
- Self draining
- Soft seat capability for ANSI Class VI shutoff
- No guiding surface in the fluid
- Stainless steel regulators
- Nickel alloy regulators
- PVDF regulators
- Sanitary regulators
- Cleaning-in-Place (CIP)
- Steaming-in-Place (SIP)

## Technical Data

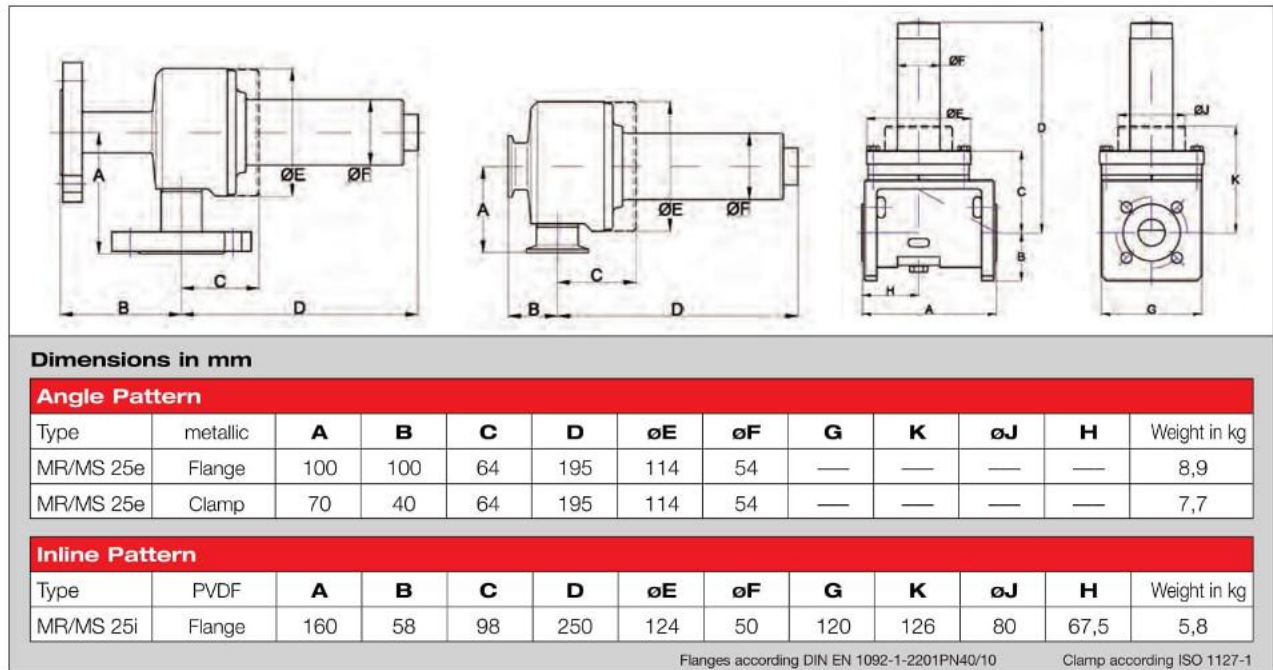

### Technical Data

Max. inlet pressure	: 16 bar / 300 psi
	: (10 bar / 150 psi for PVDF regulators)
Max. vacuum	: Withstands full vacuum
Regulating range with springs	: 0 to 5 bar / 0 to 70 psi
Regulating range dome loaded	: 0 to 16 bar / 300 psi (0 to 10 bar / 150 psi for PVDF Regulators)
Max. temp. FFKM (Kalrez®)	: -20°C to +160°C / -4°F to +320°F
Max. temp. FPM (Viton®)	: -20°C to +120°C / -4°F to +248°F
Max. temp. PVDF	: -20°C to +130°C / -4°F to +260°F

Seat tightness acc. to EN 12266-1,	
leaking rate A, P12 / ANSI Class VI shutoff	
Flow capacity for adjustment	: 1 Nm <sup>3</sup> /h

### Certificates

According to Pressure Equipment Directive	: PED 97/23/EG
Statement of Compliance	: US.FDA 21 CFR
Work Certificate	: EN10204 3.1

### Installation

Basically the regulators may be installed in every mounting position as long as the flow direction will be as indicated on the body. To ensure selfdraining for angle pattern design regulators, they should be installed shown as follows. Inline design regulators (PVDF) are not selfdraining. The regulators should be installed, that the springhousing ventbore is protected from anything that might interfere with it.

