

Codification Mediumpressure Regulators

1. Functions	2. Connections	3. Bodies	4. Accessories
MR Reducer	A ANSI Flanges 150 lbs	S 316 L (1,4404)	H Heating Jacket
MRC Sanitary-Reducer	D DIN Flanges PN16 / PN10	H Nickel alloy	P Adjusted and Sealed
... P Pilot Pressure Design	C1 Clamp ISO 1127-1	P PVDF	M Pressure Gauge
	C2 Clamp DIN 32676	X Special	V Pressure Gauge Fitting
MS Back Pressure Regulator	C3 Clamp OD / ASME		X Special
MSC Sanitary-Back Pressure Regulator	C4 Clamp SMS	Trim Parts	
... P Pilot Pressure Design	C5 Food Union DIN 11851	S 316 L (1,4404)	
	G BSP Thread fem	H Nickel alloy	
	N NPT Thread fem	P PVDF	
	S Flanges with slot DIN 2512	X Special	
	X Special		
Sizes	Seats Ø	Seats O-Ring	
25 DN 25 (1")	(06,10,14)R Direct Action	K FFKM (Kalrez® 6375)	
	(14,21)S Relief Seat	V FPM (Viton®)	
		C FFKM FDA (Kalrez® 6221)	
		X Special	
	Springs		
Patterns	L 0.04 to 0.25 bar / 0. to 0.15 psi	Diaphragms	
i Inline Pattern	A 0.15 to 1 bar / 1.5 to 15 psi	P PTFE	
e Angle Pattern	B 0.4 to 3 bar / 6 to 40 psi	V FPM	
	C 0.6 to 5 bar / 12 to 70 psi	E EPDM white FDA	
	J Dome Loaded	X Special	
	X Special		

Examples:

1 **2** **3** **4**
MR25e **D06RA** **SSV** **P**

- 1 Reducer DN 25, angle pattern
- 2 DIN flanges PN 40, seat diameter 6 mm, direct action, spring range 0.15 to 1 bar
- 3 Body stainless steel, trim parts stainless steel, seat o-ring material FPM, diaphragm FPM
- 4 Adjusted and lead sealed

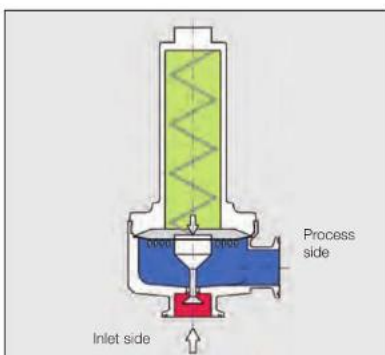

Reducing Regulator Function

Spring-loaded pressure reducing regulators are "relative pressure regulators", designed to keep the process pressure at a constant level. The nominal pressure is set by means of the setscrew, located at the spring housing. When at rest, the regulator remains in an open position. When the pressure rises, pressure is released through the open valve seat to the process side of the valve underneath the diaphragm. This will continue, until the diaphragm force exceeds the spring force, while the process pressure rises. The diaphragm is lifted and the valve seat closes. In the event that the process pressure drops below the preadjusted nominal pressure, the spring force presses the diaphragm downwards, so that the valve seat opens and admits gas until pressure equalization is reached again.

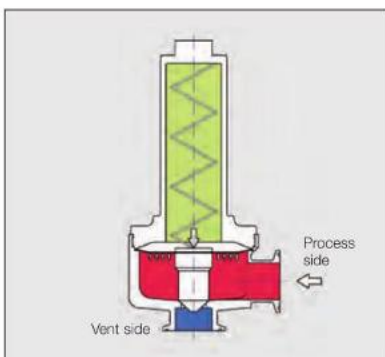

Back Pressure Regulator Function

Spring-loaded back pressure valves are "relative pressure regulators", designed to keep the process pressure at a constant level. The nominal pressure is set by means of the setscrew, located at the spring housing. When at rest, the regulator remains in a closed position. If the process pressure increases, the force underneath the diaphragm increases as well. If the diaphragm force exceeds the spring force, the valve seat opens and the over pressure is discharged to the vent side. If the process pressure drops, the diaphragm force is lower compared to the spring force and the valve seat closes. The pressure in the vent line can be atmospheric or vacuum. With vacuum in the vent line the flow capacity of the regulator is increased.



Technology for the professionals

Tank Blanketing Regulators

Low-Pressure Reducing Regulator
Type BR

Low-Pressure Relief Valve
Type BS

MADE  SWISS



Description

Low-pressure reducing and relief valves regulate pressures in mbar range and serve the inertisation and blanketing of containers, reactors, stirrer vessels, centrifuges, etc. with inert gas such as nitrogen.

Inertisation

For discontinuous batch processes before process start, the reactor chamber is rendered inert. The inertisation of spaces describes the process to displace the oxygen in the air or other reactive or explosive gases or gas compounds by adding of inert gas.



Ventilation/Blanketing

Aim of ventilation/protective gas blanketing is maintaining the inert condition inside the reactor, tank or container during the manufacturing process.

Highlights

- Regulating pressures up to 1000 mbar
- Nominal diameters DN15 - DN100
- DN15 - DN50 PN16
- DN80 - DN100 PN10
- 1/2"-4" ANSI/ASME 150 lbs
- Counterpressure-resistant up to 2 bar
- Vacuum-resistant
- Stainless steel regulators
- Nickel alloy regulators
- Clean regulators
- Low-maintenance (friendly)
- ATEX optional

Technical Data

Nominal Pressure Rating

Stainless steel casing	: DN15 to DN50	16 bar
	DN80 to DN100	10 bar
Max. inlet pressure	: up to DN50 ≤ 50°C	16 bar
	at max. 150°C	13 bar
	DN80 – DN100 ≤ 50°C	10 bar
	at max. 150°C	8 bar
Max. negative pressure	: vacuum-resistant	
Control range springs	: -200 to 1000 mbar	
Control range pilot pressure	: -200 to 2000 mbar	
Max. temp. FFKM (Kalrez®)	: -20°C to +150°C	
Max. temp. PKM (Viton®)	: -20°C to +120°C	
Max. temp. PVDF	: -20°C to +130°C	

Seat Tightness/Standard Setting

Seat tightness according to P12; EN 12266-1:2003;		leakage rate A
Flow rate at standard setting:	DN 15 / 1/2"	: 0.5 Nm ³ /h
	DN 25 / 1"	: 1 Nm ³ /h
	DN 40 / 1 1/2"	: 2 Nm ³ /h
	DN 50 / 2"	: 2 Nm ³ /h
	DN 80 / 3"	: 5 Nm ³ /h
	DN 100 / 4"	: 5 Nm ³ /h

Designs/Certificates

Design according to pressure equipment directive	: DGR 97/23/EG
Marking ≥ DN32	: CE0036
Declaration of Conformity QS 04 ATEX 2006	: II 2GD opt. IIC
FDA conformity for elastomers:	: US.FDA 21 CFR
Factory Acceptance Certificate:	: EN10204 2.2
	: EN10204 3.1

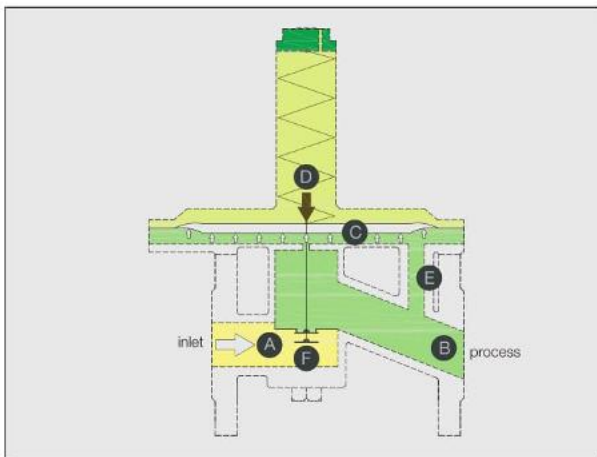

Reducing Regulator Function

Spring-loaded pressure reducing regulators are "relative pressure regulators", designed to keep the process pressure "B" at a constant level. The nominal pressure is set by means of the setscrew, located at the spring housing. When at rest, the regulator remains in an open position. When the pressure "A" rises, pressure is released through the open valve seat "F" to the process side of the valve and through the internal feedback bore "E" underneath the diaphragm. This will continue, until the diaphragm force "C" exceeds the spring force "D", while the process pressure "B" rises. The diaphragm is lifted and the valve seat "F" closes. In the event that the process pressure "B" drops below the pre-adjusted nominal pressure, the spring force "D" presses the diaphragm downwards, so that the valve seat "F" opens and admits gas until pressure equalization is reached again.

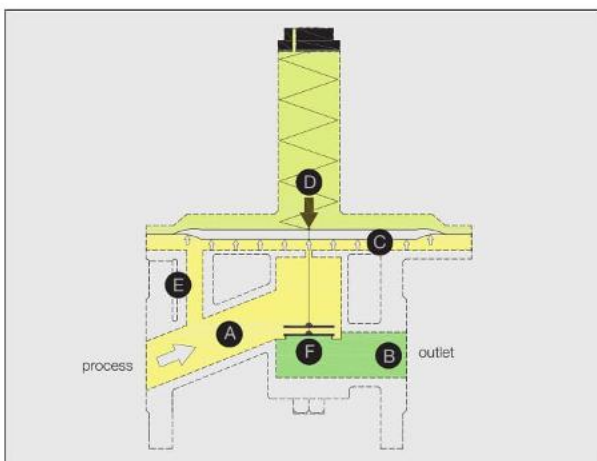







Relief Valve Function

Spring-loaded relief valves are "relative pressure regulators", designed to keep the process pressure "A" at a constant level. The nominal pressure is set by means of the setscrew, located at the spring housing. When at rest, the regulator remains in a closed position. When the process pressure "A" increases, pressure is released through the internal feedback bore "E" underneath the diaphragm. If the diaphragm force "C" exceeds the spring force "D" the valve seat "F" opens and the over pressure is discharged to the vent side "B". If the process pressure "A" drops, the diaphragm force "C" is lower compared to the spring force "D" and the valve seat "F" closes. The pressure in the vent line can be atmospheric or vacuum. With vacuum in the vent line the flow capacity of the regulator is increased.























Wipers

Profile	Type	Standardmaterial	Pressure (bar)	Temp. (°C)	Surface speed (m/sec)
	WR01	PU NBR	-	-30 to 105 -25 to 100	4
	WR01A	PU NBR	-	-30 to 105 -25 to 100	4
	WR02	PU NBR	-	-30 to 105 -25 to 100	4
	WR02A	PU NBR	-	-30 to 105 -25 to 100	4
	WR02B	PU NBR	-	-30 to 105 -25 to 100	4
	WR02C	PU NBR	-	-30 to 105 -25 to 100	4
	WR02D	PU PU-D57	-	-30 to 105	4
	WR03	PU/POM * NBR/POM *	-	-30 to 105 -25 to 100	4
	WR04	PU NBR	-	-30 to 105 -25 to 100	4
	WR07	POM PA PU-D57	-	-50 to 80 -50 to 80 -30 to 105	1
	WR08	POM PA PU-D57	-	-50 to 80 -50 to 80 -30 to 105	1
	WR11	PU NBR	-	-30 to 105 -25 to 100	4
	WR12	PU NBR	-	-30 to 105 -25 to 100	4
	WR13	PTFE/NBR	15	-25 to 100	10
	WR13_E2	PTFE/NBR	15	-25 to 100	10
	WR14	PTFE/NBR	15	-25 to 100	10
	WR15	PTFE/NBR	15	-25 to 100	10
	WR17	PU NBR	-	-30 to 105 -25 to 100	4
	WR18	PU NBR	-	-30 to 105 -25 to 100	4

* For technical reasons POM should be used up to a maximum temperature of 80° C only. For higher temperature we recommend Aluminum/Steel.

Rod seals

Profile	Type	Standardmaterial	Pressure (bar)	Temp. (°C)	Surface speed (m/sec)
	RS01	PU NBR FPM	400 160 160	-30 to 105 -25 to 100 -20 to 210	0,5
	RS01A	PU NBR FPM	300 160 160	-30 to 105 -25 to 100 -20 to 210	0,5
	RS01B	PU NBR FPM	400 160 160	-30 to 105 -25 to 100 -20 to 210	0,5
	RS01C	NBR FPM	160 160	-25 to 100 -20 to 210	1
	RS02	PU/POM NBR/POM FPM/PTFE	700 250 250	-30 to 100 -25 to 100 -20 to 210	0,5
	RS02A	PU/POM NBR/POM FPM/PTFE	700 250 250	-30 to 100 -25 to 100 -20 to 210	0,5
	RS02B	PU/PTFE	700	-30 to 105	0,5
	RS02C	PU/POM	400	-25 to 100	5
	RS03	PU/NBR	400	-25 to 100	0,5
	RS04	PU/NBR/POM	700	-25 to 100	0,5
	RS05	PU NBR	25	-30 to 105 -25 to 100	1
	RS08	PU NBR	400 160	-30 to 105 -25 to 100	0,3
	RS09	PU-D57/NBR PTFE/NBR	600	-25 to 100	5 10
	RS09A	PU-D57/NBR PTFE/NBR	600	-25 to 100	5 10
	RS09B	PU-D57/NBR PTFE/NBR	600	-25 to 100	5 10
	RS91	PU-D57/NBR PTFE/NBR	600	-25 to 100	5 10
	RS91B	PU-D57/NBR PTFE/NBR	600	-25 to 100	5 10
	RS16	PU NBR	160	-30 to 105 -25 to 100	0,5
	RS17	PU NBR	400 160	-30 to 105 -25 to 100	0,5
	RS17A	PU/POM	700	-30 to 100	0,5

Rod seals

Profile	Type	Standardmaterial	Pressure (bar)	Temp. (°C)	Surface speed (m/sec)
	RS17B	PU/NBR	400	-25 to 100	0,5
	RS17C	PU/NBR/POM	700	-25 to 100	0,5
	RS17D	PU NBR	400 160	-30 to 105 -25 to 100	0,3
	RS17E	PU/POM	700	-30 to 100	0,3
	RS19	PTFE-virgin / V-spring PTFE-filled / V-spring	200 400	-200 to 260	15
	RS19A	PTFE/V-spring	150	-200 to 260	2
	RS20	NBR/POM	700	-25 to 100	0,5
	RS31-33	PU/POM	500	-30 to 100	0,5
	RS35	PU	400	-30 to 105	0,4



















Piston seals

Profile	Type	Standardmaterial	Pressure (bar)	Temp. (°C)	Surface speed (m/sec)
	PS01	PU NBR FPM	400 160 160	-30 to 105 -25 to 100 -20 to 210	0,5
	PS01A	PU NBR FPM	300 160 160	-30 to 105 -25 to 100 -20 to 210	0,5
	PS01B	PU NBR FPM	400 160 160	-30 to 105 -25 to 100 -20 to 210	0,5
	PS01C	NBR FPM	160 160	-25 to 100 -20 to 210	1
	PS02	PU/POM NBR/POM FPM/PTFE	700 250 250	-30 to 100 -25 to 100 -20 to 210	0,5
	PS02A	PU/POM NBR/POM FPM/PTFE	700 250 250	-30 to 100 -25 to 100 -20 to 210	0,5
	PS03	PU/NBR	400	-25 to 100	0,5
	PS04	PU/NBR/POM	700	-25 to 100	0,5
	PS05	PU NBR	25	-30 to 105 -25 to 100	1

Piston seals

Profile	Type	Standardmaterial	Pressure (bar)	Temp. (°C)	Surface speed (m/sec)
	PS08	PU-D57/NBR PTFE/NBR	600	-25 bis 100	5 15
	PS08A	PU/NDR PU-D57/NBR PTFE/NBR	250 400 400	-25 to 100	1 5 15
	PS08B	PU-D57/NBR PTFE/NBR	600	-25 to 100	5 10
	PS08C	PTFE/NBR	400	-25 to 100	2
	PS08D	PTFE/NBR	400	-25 to 100	3
	PS08E	PU-D57/NBR PTFE/NBR	600	-25 to 100	5 10
	PS08F	PU-D57/NBR PU/NBR	400 250	-25 to 100	5 1
	PS81	PU-D57/NBR PTFE/NBR	600	-25 to 100	5 10
	PS81B	PU-D57/NBR PTFE/NBR	600	-25 to 100	5 10
	PS09	PU/NBR/POM	400	-25 to 100	0,5
	PS09A	PTFE/NBR/POM	400	-25 to 100	1
	PS16	PU NBR	160	-30 to 105 -25 to 100	0,5
	PS16A	PU NBR	160	-30 to 105 -25 to 100	0,5
	PS17	PU/POM NBR/POM	400 250	-25 to 100	0,5
	PS17A	PU/POM NBR/POM	400 250	-25 to 100	0,5
	PS17B	PU/POM NBR/POM	400 250	-25 to 100	0,5
	PS19	PTFE-virgin / V-spring PTFE-filled / V-spring	200 400	-200 to 260	15
	PS19A	PTFE-virgin / V-spring PTFE-filled / V-spring	200 400	-200 to 260	2
	PS20	NBR/POM	700	-25 to 100	0,5
	PS23	PU/NBR/POM	400	-25 to 100	0,5
	PS35	PU	400	-30 to 105	0,4









Symmetrical seals | Piston-, Rod seals

Profile	Type	Standardmaterial	Pressure (bar)	Temp. (°C)	Surface speed (m/sec)
	PRS06	PU NBR	400 160	-30 to 105 -25 to 100	0,5
	PRS06A	PU NBR	300 160	-30 to 105 -25 to 100	0,5
	PRS06B	PU NBR	400 160	-30 to 105 -25 to 100	0,5
	PRS06C	PU NBR	400 160	-30 to 105 -25 to 100	0,3
	PRS06D	PU NBR	400 160	-30 to 105 -25 to 100	0,5
	PRS06E	PU NBR	400 160	-30 to 105 -25 to 100	0,5
	PRS07	PU/NBR	400	-25 to 100	0,5
	PRS10SP	PU FPM POM	-	-30 to 105 -20 to 210 -60 to 100	-
	PRS10-12	PU/POM NBR/POM	500 250	-30 to 100 -25 to 100	0,5
	PRS13-15	PU/POM NBR/POM	500 250	-30 to 100 -25 to 100	0,5
	PRS18	PU/NBR	400	-25 to 100	0,5
	PRS19	PTFE-virgin / V-spring PTFE-filled / V-spring	200 400	-200 to 260	15
	PRS19B	PTFE-virgin / Helicoil Spring PTFE-filled / Helicoil Spring	200 400	-200 to 260	5
	PRS19C	PTFE-virgin / Helicoil Spring PTFE-filled / Helicoil Spring	200 400	-200 to 260	5
	PRS19D	PTFE-virgin / Helicoil Spring PTFE-filled / Helicoil Spring	200 400	-200 to 260	5
	PRS22	PU/POM NBR/POM FPM/PTFE	400 160 160	-30 to 100 -25 to 100 -20 to 210	0,5
	PRS25-27	PTFE-virgin PTFE-filled	100	-200 to 260	1,5
	PRS99	PU NBR FPM	400 160 160	-30 to 105 -25 to 100 -20 to 210	0,5

Back-up rings





















Profile	Type	Standardmaterial	Pressure (bar)	Temp. (°C)	Surface speed (m/sec)
	BUR08	POM PTFE	-	-60 to 100 -200 to 260	-
	BUR09	POM PTFE	-	-60 to 100 -200 to 260	-
	BUR10	POM PTFE	-	-60 to 100 -200 to 260	-
	BUR11	POM PTFE	-	-60 to 100 -200 to 260	-
	BUR12	POM PTFE	-	-60 to 100 -200 to 260	-
	BUR13	POM PTFE	-	-60 to 100 -200 to 260	-

Guide rings

Profile	Type	Standardmaterial	Pressure (bar)	Temp. (°C)	Surface speed (m/sec)
	BWR01	POM PTFE Polyester-fabric*	-	-60 to 100 -200 to 260 -40 to 130	4
	BWR01A	POM PTFE	-	-60 to 100 -200 to 260	4
	BWR03	POM PTFE	-	-60 to 100 -200 to 260	4
	BWR04	POM PTFE	-	-60 to 100 -200 to 260	4
	BWR05	POM PTFE	-	-60 to 100 -200 to 260	4
	BWR06	POM PTFE	-	-60 to 100 -200 to 260	4
	BWR07	POM PTFE	-	-60 to 100 -200 to 260	4
	BWR08	POM PTFE	-	-60 to 100 -200 to 260	4
	BWR09	-	-	-	-

*Various dimensions available in reels.

Rotary seals







Profile	Type	Standardmaterial	Pressure (bar)	Temp. (°C)	Surface speed (m/sec)
	OS01	PU/POM* NBR/POM* FPM/PTFE	0,5 0,5 0,5	-30 to 100 -25 to 100 -20 to 210	5 10 15
	OS02	PU/POM* NBR/POM* FPM/PTFE	0,5 0,5 0,5	-30 to 100 -25 to 100 -20 to 210	5 10 15
	OS03	PU NBR FPM	0,5 0,5 0,5	-30 to 100 -25 to 100 -20 to 210	5 10 15
	OS08	PU NBR	-	-30 to 105 -25 to 100	5 10
	OS08A	PU NBR	-	-30 to 105 -25 to 100	5 10
	R03	PU/POM NBR/POM	400 250	-30 to 100 -25 to 100	0,2 0,2
	R04	PU NBR	160 100	-30 to 105 -25 to 100	0,2 0,2
	R04A	PU NBR	160 100	-30 to 105 -25 to 100	0,2 0,2
	R05	PU NBR	160 100	-30 to 105 -25 to 100	0,2 0,2
	R05A	PU NBR	160 100	-30 to 105 -25 to 100	0,2 0,2
	VR06	NBR	-	-25 to 100	25
	VR07	NBR	-	-25 to 100	25
	R08	PTFE/NBR	350	-25 to 100	0,4
	R08D	PTFE/NBR	350	-25 to 100	0,4
	R09	PTFE/NBR	350	-25 to 100	0,4
	R09A	PTFE/NBR	350	-25 to 100	0,4
	R10	PTFE/NBR	350	-25 to 100	0,4
	R10A	PTFE/NBR	350	-25 to 100	0,4
	R11	PTFE/NBR	350	-25 to 100	0,4
	R11D	PTFE/NBR	350	-25 to 100	0,4

* For technical reasons POM should be used up to a maximum temperature of 80° C only. For higher temperature we recommend Aluminum/Steel.















Static seals and O-rings

Profile	Type	Standardmaterial	Pressure (bar)	Temp. (°C)	Surface speed (m/sec)
	FL01A	PU FPM EPDM	400 250 250	-30 to 105 -20 to 210 -50 to 130	-
	FL02B	PU FPM EPDM	400 250 250	-30 to 105 -20 to 210 -50 to 130	-
	FL03	PU NBR FPM	600 250 250	-30 to 105 -25 to 100 -20 to 210	-
	FL06	PTFE-virgin / Helicoil Spring PTFE-filled / Helicoil Spring	200 400	-60 to 200	0,1
	FL07	PTFE-virgin / Helicoil Spring PTFE-filled / Helicoil Spring	200 400	-60 to 200	0,1
	OR	PU NBR FPM	600 160 160	-30 to 105 -25 to 100 -20 to 210	-
	ORH	PU NBR FPM	600 160 160	-30 to 105 -25 to 100 -20 to 210	-
	ORV	PU NBR FPM	600 160 160	-30 to 105 -25 to 100 -20 to 210	-
	QR01	PU NBR FPM	600 160 160	-30 to 105 -25 to 100 -20 to 210	-
	QR02	PU NBR FPM	600 160 160	-30 to 105 -25 to 100 -20 to 210	-
	SS01	PU NBR FPM	600 250 250	-30 to 105 -25 to 100 -20 to 210	-





Customized seals and machined parts

Profile					
					
					

Mining seals

Profile	Type	Standardmaterial	Pressure (bar)	Temp. (°C)	Surface speed (m/sec)
	P50	PU/POM	400 dyn. 1500 stat.**	-30 to 100	0,5 0,2
	P50A	PU/POM	400 dyn. 1500 stat.**	-30 to 100	0,5 0,2
	P51	PU/NBR/POM	400 dyn. 1500 stat.**	-25 to 100	0,5 0,2
	P51A	PU/NBR/POM	400 dyn. 1500 stat.**	-25 to 100	0,5 0,2
	P51G	PU/NBR/POM	400 dyn. 1500 stat.**	-25 to 100	0,5 0,2
	P52	PU/POM	700 dyn. 1500 stat.**	-30 to 100	0,5 0,2
	P53	PU/NBR/POM	700 dyn. 1500 stat.**	-25 to 100	0,5 0,2
	P54	PU/NBR/POM	400 dyn. 1500 stat.**	-25 to 100	0,5 0,2
	P54A	PU/NBR/POM	400 dyn. 1500 stat.**	-25 to 100	0,5 0,2
	P55	PU/POM NBR/POM	700 dyn./1500 stat.** 400 dyn./1500 stat.**	-25 to 100	0,5/0,2 0,5/0,2
	R50	PU/NBR/POM	700	-25 to 100	0,5
	R50A	PU/NBR/POM	700	-25 to 100	0,5
	R51	PU/NBR	400	-25 to 100	0,5
	R52	PU/POM	700	-30 to 100	0,5
	R53	PU	400	-30 to 105	0,5
	W50	PU	-	-30 to 105	2
	W51	PU	-	-30 to 105	2

Mining seals

Profile	Type	Standard material	Pressure (bar)	Temp. (°C)	Surface speed (m/sec)
	W53	PU/POM*	-	-30 to 80	2
	W54	PU	-	-30 to 105	2
	BWR01-P	POM PTFE	-	-60 to 100 -200 to 260	4
	BWR01-R	POM PTFE	-	-60 to 100 -200 to 260	4
	P58	PU	400	-30 to 105	0,3

* For technical reasons POM should be used up to a maximum temperature of 80° C only. For higher temperature we recommend Aluminum/Steel.

** The maximum pressure allowance for dynamic and static application is dependent on the profile design.



















i















The listed application parameters represent only a guide and should not occur simultaneously. Pressure, speed, temperature as well as the gap dimension, but also the fluid itself are determining factors which influence each other. The data refer to the generally valid and known data in the seal technology. By means of a careful selection of specific materials for the different applications the documented data may be optimized accordingly.

The seal geometries shown in the profile synopses are standard profiles. In addition, all the profiles can get adapted to special working conditions. Besides the listed standard profiles we deliver special profiles according to customer's drawings which match the individual requirements. All seals are turned workpieces up to an outside diameter of 1.850 mm and can get delivered with short notice



Table of materials

	Description	Color	Application temp.	Hardn. at 20°C	Main application
POLYURETHANE * all Polyurethane grades resistant to hydrolysis	PU U500-R95 red		-30 to +125°C	Shore A 95 +/-2	Lip seals, wiper rings, vee packings and other seal elements Mineral oils, HFA, HFB fluids, water, sea water, dilute acids and alkaline solutions Improved chemical and thermal resistance excellent wear and friction properties
	PU U510-G88 light green		-30 to +115°C	Shore A 90 +/-2	Lip seals, wiper rings, vee packings and other seal elements Mineral oils, HFA, HFB fluids, water, sea water, dilute acids and alkaline solutions Application for pneumatic and low pressure
	PU U520-OR95-HT orange		-30 to +135°C	Shore A 96 +/-2	Lip seals, wiper rings, vee packings and other seal elements Mineral oils, HFA, HFB fluids, water, sea water, dilute acids and alkaline solutions Applications at high temperature
	PU U530-B95-LT light blue		-50 to +105°C	Shore A 95 +/-2	Lip seals, wiper rings, vee packings and other seal elements Mineral oils, HFA, HFB fluids, water, sea water Applications at low temperature
	PU U540-VI95-CR violet		-30 to +115°C	Shore A 95 +/-2	Lip seals, wiper rings, vee packings and other seal elements Mineral oils, HFA, HFB fluids, water, sea water Improved chemical resistance, suitable for CIP processes Applicable for contact with foodstuff
	PU U550-GM95 dark red		-30 to +125°C	Shore A 95 +/-2	Lip seals, wiper rings, vee packings and other seal elements Mineral oils, HFA, HFB fluids, water, sea water Improved wear and friction properties for waterhydraulics and heavy duty applications with low lubrication
	PU U570-D57 blue		-30 to +125°C	Shore D 57 +/-3	Lip seals, wiper rings, vee packings and other seal elements Mineral oils, HFA, HFB fluids, water, sea water High pressure and extrusion resistance
	PU U580-D57G grey		-30 to +125°C	Shore D 57 +/-3	Back-up rings or composite seals with preload element Mineral oils, HFA, HFB fluids, water, sea water High pressure and extrusion resistance Improved wear and friction properties
	PU U203-G95 green		-30 to +105°C	Shore A 95 +/-2	Lip seals, wiper rings, vee packings and other seal elements Mineral oils, HFA, HFB fluids, water, sea water
NBR	NBR N107-B85 black		-25 to +100°C	Shore A 85 +/-5	Lip seals, wiper rings, vee packings and other seal elements Mineral oils, HFA, HFB, HFC fluids, cold water
	NBR 95 N109-B95 black		-25 to +100°C	Shore A 95 +/-5	Lip seals, wiper rings, vee packings and other seal elements Mineral oils, HFA, HFB, HFC fluids, cold water
	NBR FDA N111-W85 white		-22 to +100°C	Shore A 85 +/-3	Lip seals, wiper rings, vee packings and other seal elements Mineral oils, HFA, HFB, HFC fluids, cold water Applicable for contact with foodstuff
H-NBR	H-NBR HN112-B85 black		-25 to +150°C	Shore A 85 +/-5	Lip seals, wiper rings, vee packings and other seal elements Mineral oils, HFA, HFB, HFC fluids at high temperature Aliphatic hydrocarbons, dilute acids and bases
	H-NBR RGD HN900-B85-RGD black		-20 to +150°C	Shore A 85 +/-5	Lip seals, wiper rings, vee packings and other seal elements Mineral oils, HFA, HFB, HFC fluids at high temperature Aliphatic hydrocarbons, dilute acids and bases RGD (ED) optimized for use in Oil & Gas Industry
	H-NBR RGD LT HN901-B85-RGD black		-40 to +150°C	Shore A 85 +/-5	Lip seals, wiper rings, vee packings and other seal elements Mineral oils, HFA, HFB, HFC fluids at high temperature Aliphatic hydrocarbons, dilute acids and bases RGD (ED) optimized for low temperature use in Oil & Gas Industry Meets the Norsok M-710 requirements
FPM	FPM F109-BR85 brown		-20 to +210°C	Shore A 85 +/-5	Lip seals, wiper rings, vee packings, oil seals at high speed and other seal elements Mineral oils, HFD fluids at high temperature Very good chemical resistance such as phosphates and chlorinated hydrocarbons, crude and sour gas
	FPM FDA F110-BR85 brown		-25 to +210°C	Shore A 85 +/-5	Mineral oils, HFD fluids at high temperature Very good chemical resistance such as phosphates and chlorinated hydrocarbons, crude and sour gas Applicable for contact with foodstuff
	FPM F111-B85 black		-25 to +210°C	Shore A 85 +/-5	Lip seals, wiper rings, vee packings, oil seals at high speed and other seal elements Mineral oils, HFD fluids at high temperature Very good chemical resistance such as phosphates and chlorinated hydrocarbons, crude and sour gas
	FPM-RGD F800-B85-RGD black		-30 to +210°C	Shore A 85 +/-5	Lip seals, wiper rings, vee packings and other seal elements Mineral oils, HFD fluids at high temperature Very good chemical resistance such as phosphates and chlorinated hydrocarbons, crude and sour gas RGD (ED) optimized for use in Oil & Gas Industry Meets the Norsok M-710 requirements

	Description	Color	Application temp.	Hardn. at 20°C	Main application
EPDM	EPDM E131-B85 black		-50 to +130°C	Shore A 85 +/-5	Lip seals, vee packings and other seal elements Hot water and steam, ozone, dilute acids and alkaline solutions. EPDM is NOT resistant against mineral oils
	EPDM FDA E132-W85 white		-50 to +100°C	Shore A 85 +/-3	Lip seals, vee packings and other seal elements Hot water and steam, ozone, dilute acids and alkaline solutions. EPDM is NOT resistant against mineral oil Applicable for contact with foodstuff
	EPDM KTW E133-W270 black		-45 to +120°C	Shore A 85 +/-5	Lip seals, vee packings and other seal elements Hot water and steam, dilute acids and alkaline solutions. EPDM is NOT resistant against mineral oil Applicable for use in drinking water
SILICONE	Silicone FDA S102-R85 red		-55 to +210°C	Shore A 85 +/-5	Flange seals, gaskets and other static seals Mineral oils, HFA, HFB, HFC, HFD fluids, ozone Not recommended for dynamic applications Applicable for contact with foodstuff
	Silicone FDA S103-BL85 blue		-55 to +180°C	Shore A 85 +/-3	Flange seals, gaskets and other static seals Mineral oils, HFA, HFB, HFC, HFD fluids, ozone Not recommended for dynamic applications Applicable for contact with foodstuff
TFEP	AFLAS AF101-B85 black		-15 to +210°C	Shore A 85 +/-5	Lip seals, vee packings and other seal elements Mineral oils, HFA, HFB, HFC, HFD fluids Hot water and steam, ozone, dilute acids and alkaline solutions, Sour oil and gas, amines
PTFE	PTFE-P FDA T101-W white		-200 to +260°C	Shore D 51 - 60	Composite seals with elastomer preload elements, spring loaded seals, Back-up and guide rings Resistance to almost all common chemicals and fluids except molten alkaline metals. Applicable for contact with foodstuff
	PTFE-F T105-G grey		-200 to +260°C	Shore D 55 - 64	Composite seals with elastomer preload elements Spring loaded seals, back-up and guide rings Resistance to almost all common chemicals and fluids except molten alkaline metals. Glass fibre / MoS2 reinforced for improved wear and extrusion resistance
	PTFE-40% T110-BR40 bronze brown		-200 to +260°C	Shore D 62 - 67	Composite seals with elastomer preload elements Resistance to almost all common chemicals except molten alkaline metals. Filled with 40% bronze for improved wear, pressure and extrusion resistance
	PTFE-25% T125-C25 carbon grey		-200 to +260°C	Shore D 62 - 67	Composite seals with elastomer preload elements Spring loaded seals, back-up and guide rings, rotary seals Resistance to almost all common chemicals except molten alkaline metals. 25% carbon powder friction properties and increased extrusion resistance
PLASTICS	POM FDA P101-WE white		-50 to +100°C	-	Back-up and guide rings, machined parts with tight tolerances Mineral oils, HFA, HFB, HFC fluids Minor absorption of water, applicable for contact with foodstuff
	PA FDA A112-WC natural		-40 to +90°C	-	Back-up and guide rings, machined parts Mineral oils, acids and dilute alkaline solutions Applicable for contact with foodstuff
	PEEK natural PK100-CN beige		-50 to +250°C	Shore D 90	Composite seals with elastomer preload elements, Back-up and guide rings high precision parts Excellent wear, friction and extrusion properties Resistance to almost all common chemicals Applicable for contact with foodstuff
	UHMW - PE PE1000-HD white		-200 to +80°C	Shore D 60 - 65	Back-up and guide rings, spring loaded seals Mineral oils, HFC, HFD fluids, acids and dilute alkaline solutions, Sour oil and gas Very low water absorption, excellent friction and wear properties Applicable for contact with foodstuff

i The indicated minimum application temperatures are thought as a general guideline, because a seal's function at low temperatures is dependent on the kind of the seal, the general application conditions, and on the kind of the surrounding metal parts the seal is in touch with. The indicated upper temperature limits may be exceeded, but this reduces the service life. Other materials available on request.

In case of doubt you are always welcome to contact our application engineers.



CHEMRAZ®

Perfluoroelastomer

THE ULTIMATE ELASTOMER

Chemraz® is a member of the perfluoroelastomer polymer family—polymers of three or more monomers in which all hydrogen positions have been replaced with fluorine. This complete state of fluorination results in outstanding resistance to heat and most chemicals and solvents. The principle monomer of Chemraz is tetrafluoroethylene (TFE); the proprietary second and third perfluorinated monomers are unique to it and confer the balance of the properties it demonstrates. Chemraz's resistance to steam and significantly improved low temperature properties are its hallmark.

Chemraz—the ultimate elastomer for demanding oilfield applications—gives excellent sealing performance when exposed to mixes of aggressive chemicals found downhole and is often specified by operators. Special compounds have been formulated for improved resistance to rapid gas decompression and abrasion, giving significant reductions in downtime and maintenance.

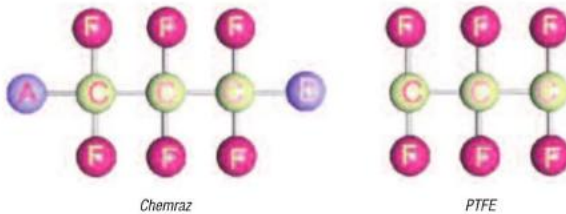

Chemraz compounds are compatible with all well fluids and gases and injection and treatment chemicals, including reservoir fluids with high H₂S content, stimulation treatment fluids, completion fluids and asphaltene removers such as Xylene and Toluene together with amine-based inhibitors. Chemraz is available in O-ring, Vee ring, G-T® ring, electrical connector boots, slabs, metal bonded seals, Arlon® thermoplastic bonded seals, miniature seals, diaphragms and custom configurations.

TYPICAL APPLICATIONS

- Subsurface safety valves
- Packers
- Geothermal applications
- Logging tools
- Wireline tools
- Drillstem test tools



CHEMRAZ COMPOUNDS

- Chemraz 505—Universal compound. High/low temperature capabilities (-22°F to 466°F, -30°C to 230°C).
- Chemraz 510—Developed specifically for O-ring applications in downhole environments. High/low temperature capabilities (-22°F to 466°F, -30°C to 230°C).
- Chemraz 526—The ultimate rapid gas decompression resistant perfluoroelastomer. High/low temperature capabilities (4°F to 482°F, -20°C to 250°C).
- Chemraz 562—The ultimate high-temperature elastomer (10°F to 600°F, -12°C to 316°C).
- Chemraz 564/566 LT—Low temperature material delivers exceptional performance in extreme environments (-40°F to 445°F, -40°C to 229°C).
- Chemraz 600—High/low temperature capabilities (-4°F to 500°F, -20°C to 260°C). Higher durometer gives greater resistance to rapid gas decompression and aggressive environments.
- Chemraz 605—High-temperature capabilities (-4°F to 500°F, -20°C to 260°C) in aggressive oilfield environments.



RAPID GAS DECOMPRESSION RESISTANCE

Rapid Gas Decompression Test Data 526 in CO₂

- Parameters
 1. Pressure—800 psi
 2. Soak Time—24 hours
 3. Temperature—ambient
 4. Media—carbon dioxide
 5. Release Rate—5 seconds to atmosphere
 6. Test Sample—AS-568 size 325 and 214 O-rings

Damage Rating Scale Modified NACE Test Method #TMO192-92

- External Visual Damage
 1. No visible damage
 2. Less than or equal to two pimples
 3. Three to ten pimples or one to two blisters
 4. Less than 5% of surface subjected to blistering
 5. Considerable damage; more than 50% of surface covered with blisters or splits
- Internal Visual Damage
 1. No visible damage
 2. Slight damage; one split/blister per cut surface
 3. Moderate damage; less than 50% of surface cut
 4. Severe damage; more than 50% of surface cut

TEST RESULTS ON CHEMRAZ® 526

Cross Section 325		Hardness M	
Initial	0.211 in. (5.36 mm)	1 Minute	91
1 Minute	0.232 in. (5.89 mm)	30 Minutes	95
30 Minutes	0.220 in. (5.58 mm)		
Damage			
External	1	Internal	1
Cross Section 214		Hardness M	
Initial	0.140 in. (3.56 mm)	1 Minute	92
1 Minute	0.149 in. (3.78 mm)	30 Minutes	95
30 Minutes	0.143 in. (3.63 mm)		
Damage			
External	1	Internal	1

GLASS TRANSITION

Lower numbers mean that elastomers will seal better at lower temperatures.

Chemraz 605 = 27°F (-3°C)

Competitive FFKM = 42°F (6°C)

LONG-TERM COMPRESSION SET EVALUATION FOR CHEMRAZ 562

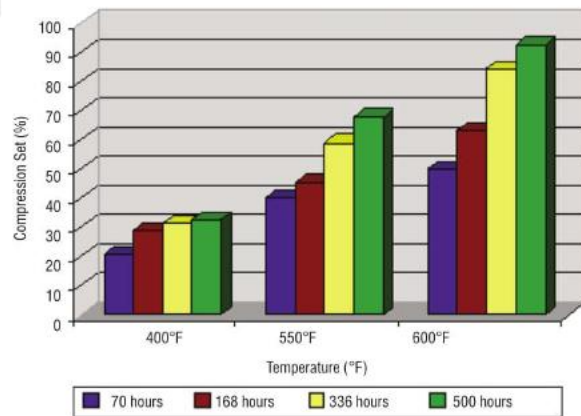



AR[®]1

ABRASIVE-RESISTANT THERMOPLASTICS

Sand and other abrasives are often a challenge for pump users in the power industry. Clearances on line shaft bearings and bowl wear rings open up, increasing pump vibrations and reducing pump efficiency. Greene, Tweed's proprietary AR[®] thermoplastic materials exhibit outstanding wear characteristics in media containing solids.

AR1 offers excellent abrasive resistance as well as chemical resistance approaching that of PTFE. AR1 is rated from ambient to 120°F (50°C). AR1 is easy to machine, and clearance requirements are easily determined. AR1 works well in a variety of pumps in the power industry including those working with circulating water, open and closed cooling water and river water as well as screen wash pumps. AR materials have performance characteristics that exceed traditional technologies such as cutlass rubber, bronze and carbon materials.

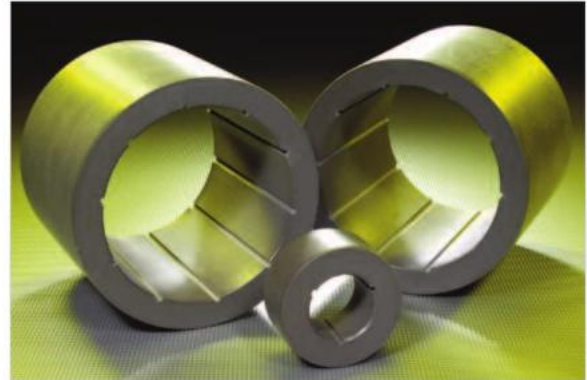

FEATURES & BENEFITS

- Improvement of pump reliability over traditional bearing materials due to lower wear in abrasive media
- Nongalling and nonseizing properties help avoid unplanned shutdowns due to pump failures caused by excessive vibration or dry-run startup
- Extends lifetime and operation of mechanical seals and pumps due to excellent vibration dampening characteristics
- Lower coefficient of friction aids survival in "off design" pump conditions, such as intermittent dry run, better than traditional materials like cutlass rubber
- Easy to machine and install to exact finished dimensions, reducing pump repair turnaround times and lowering repair costs
- Low hydrolysis or swell makes designing parts easier and helps maintain their physical properties in water applications
- Very good physical properties allow the bearings to receive impact from the shaft or shaft sleeve without breaking or cracking during operation

APPLICATIONS

- Circulating water pumps
- Open and closed cooling water pumps
- River water pumps
- Screen wash pumps
- Sump pumps

AVAILABILITY

Greene, Tweed manufactures AR1 machined components worldwide at our own QRCs (Quick Response Centers), dedicated machine centers, making them readily available in short-lead times. Greene, Tweed's on-site manufacturing capabilities allow us to produce simple or complex parts to our customers' specifications. Billet sizes range from diameters of 1 in. to 30 in. (2.5 cm to 76 cm) with lengths up to 9 in. (22.85 cm) (depending on diameter and wall thickness).



TYPICAL PROPERTIES		
Physical Properties	ASTM Method	Typical Value
Color		Brown
Specific Gravity	D1457	2.00
Hardness, Shore D, Points	D2240	65
Mechanical		
Compressive Modulus, psi (MPa)	D695	139,000 (960)
Compressive Yield Strength, psi (MPa)	D695	2,700 (19)
Elongation @ Break, %	D1457	300
Flexural Modulus, psi (MPa)	D790	157,000 (1,080)
Flexural Strength @ 5% Strain, psi (MPa)	D790	2,790 (19)
Tensile Modulus, psi (MPa)	D638	165,000 (1,140)
Tensile Strength, psi (MPa)	D4745	2,270 (16)
Thermal		
Coefficient of Thermal Expansion, in/in/°F (mm/mm/°C), (0°F to 105°F/-18°C to 41°C)	—	60 x 10 ⁻⁶ (108 x 10 ⁻⁶)
Service Temperature Range*, °F (°C)		60°F to 120°F (15°C to 50°C)

*For applications outside the suggested temperature range please contact Khong Lieng for further design assistance.

GREENE, TWEED AR® SERIES VS. TRADITIONAL MATERIALS

The chart shows percent weight change (loss) per hour of Greene, Tweed's AR materials compared to traditional materials.

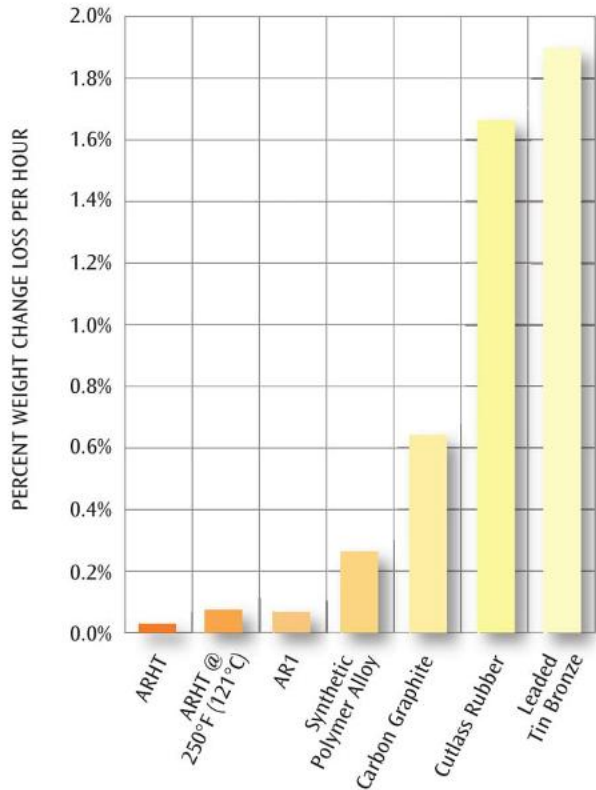

Note: Bearings made from each of the materials (size: 2 in. x 1.5 in. x 1.5 in./ 5.1 cm x 3.8 cm x 3.8 cm) were tested at 900 rpm under 25 psi (0.17 MPa). The run time of the test was eight hours. The test was conducted on 300 series SS shaft, in 95 percent water and 5 percent silica sand. All materials were tested at 70°F (20°C). Additionally, ARHT was tested at 250°F (120°C) in ethylene glycol.



Statements and recommendations in this publication are based on our experience and knowledge of typical applications of this product and shall not constitute a guarantee of performance nor modify or alter our standard warranty applicable to such products.